

BIEL14 Series

Manual LOV™ Electric Fryer



Wiring Diagrams

This manual is updated as new information and models are released. Visit our website for the latest manual.

This equipment chapter is to be installed in the Fryer Section of the *Equipment Manual*.



8 1 9 7 2 2 3
Part Number: FRY_D_8197223 06/2015



 **DANGER**

Improper installation, adjustment, maintenance or service, and unauthorized alterations or modifications can cause property damage, injury, or death. Read the installation, operating, and service instructions thoroughly before installing or servicing this equipment.

 **DANGER**

This fryer has a power cord (three-phase) for each frypot and a single five-wire cord for the entire system. Prior to movement, testing, maintenance and any repair on your Frymaster fryer; disconnect ALL electrical power cords from the electrical power supply.

BIEL14 SERIES MANUAL LOV™ ELECTRIC FRYER

Table of Contents

SECTION 1: Wiring Diagrams

- 1.1 BIEL14 Series Simplified Wiring with MLOV M3000 1-1
- 1.2 BIEL14 Series Simplified Wiring with MLOV M3000 with LON..... 1-2
- 1.3 Component Wiring with Manual LOV M3000 1-3
- 1.4 Contactor Box-Delta Configuration 1-4
- 1.5 Contactor Box-WYE Configuration..... 1-5

THIS PAGE INTENTIONALLY LEFT BLANK

BIEL14 SERIES MANUAL LOV™ ELECTRIC FRYER

SECTION 1: WIRING DIAGRAMS

1.1 BIEL14 Series Simplified Wiring with MLOV M3000

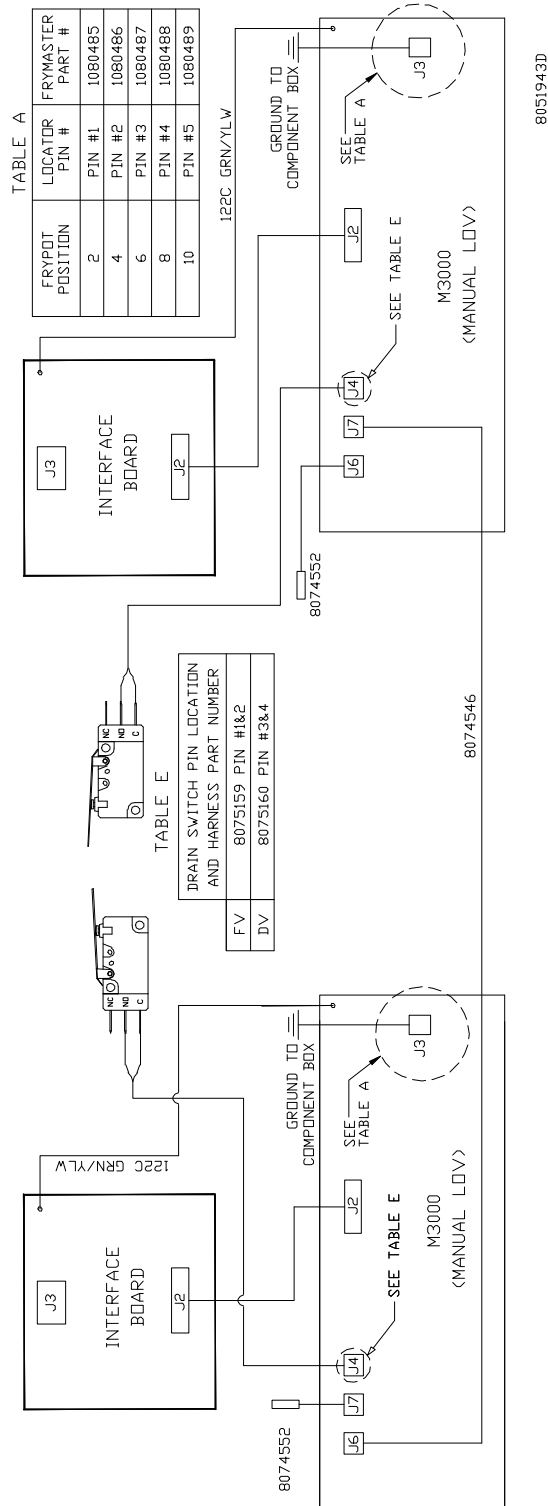

1.2 BIEL14 Series Simplified Wiring with Manual MLOV M3000 with LON

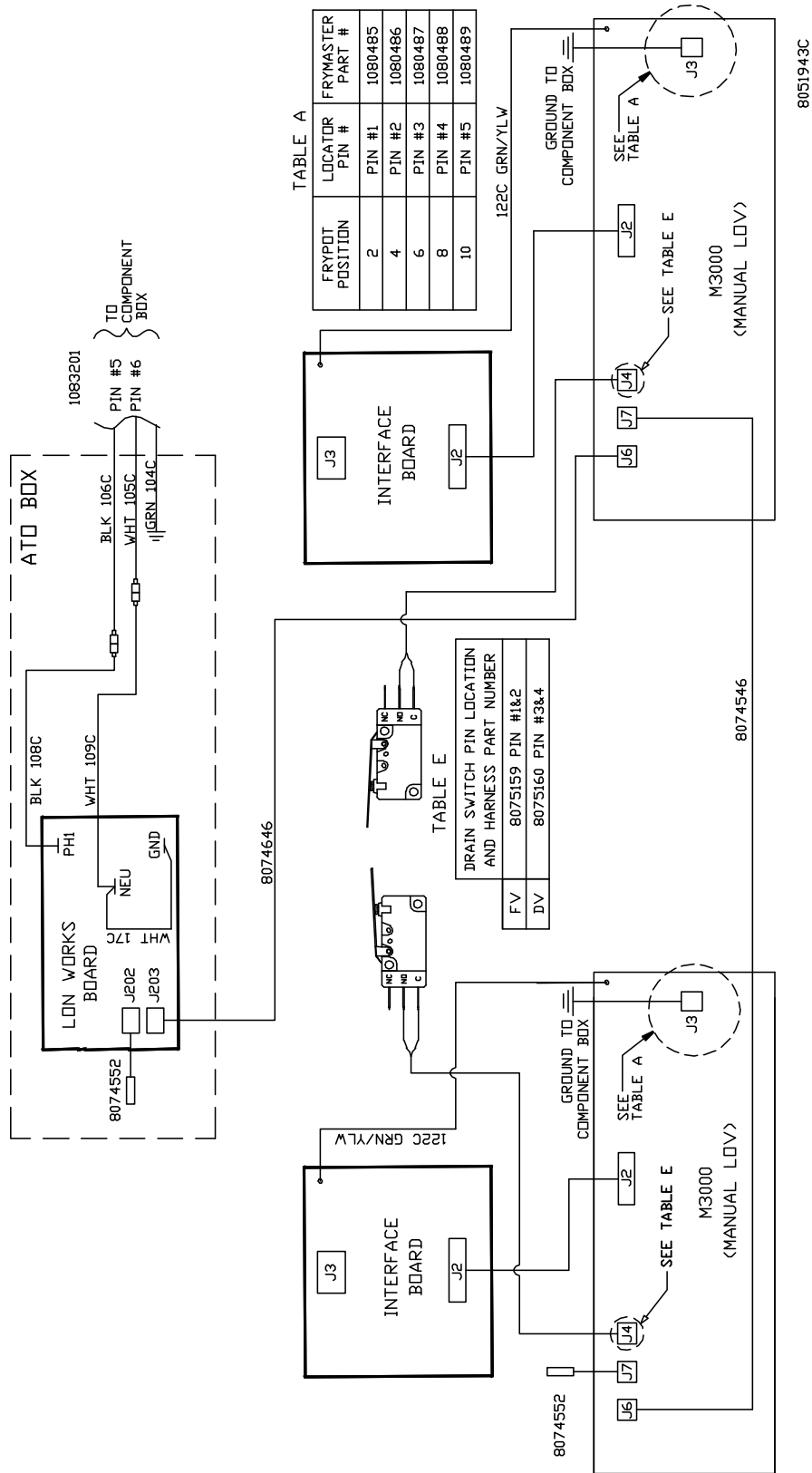

1.3a Component Wiring with Manual LOV M3000 controller

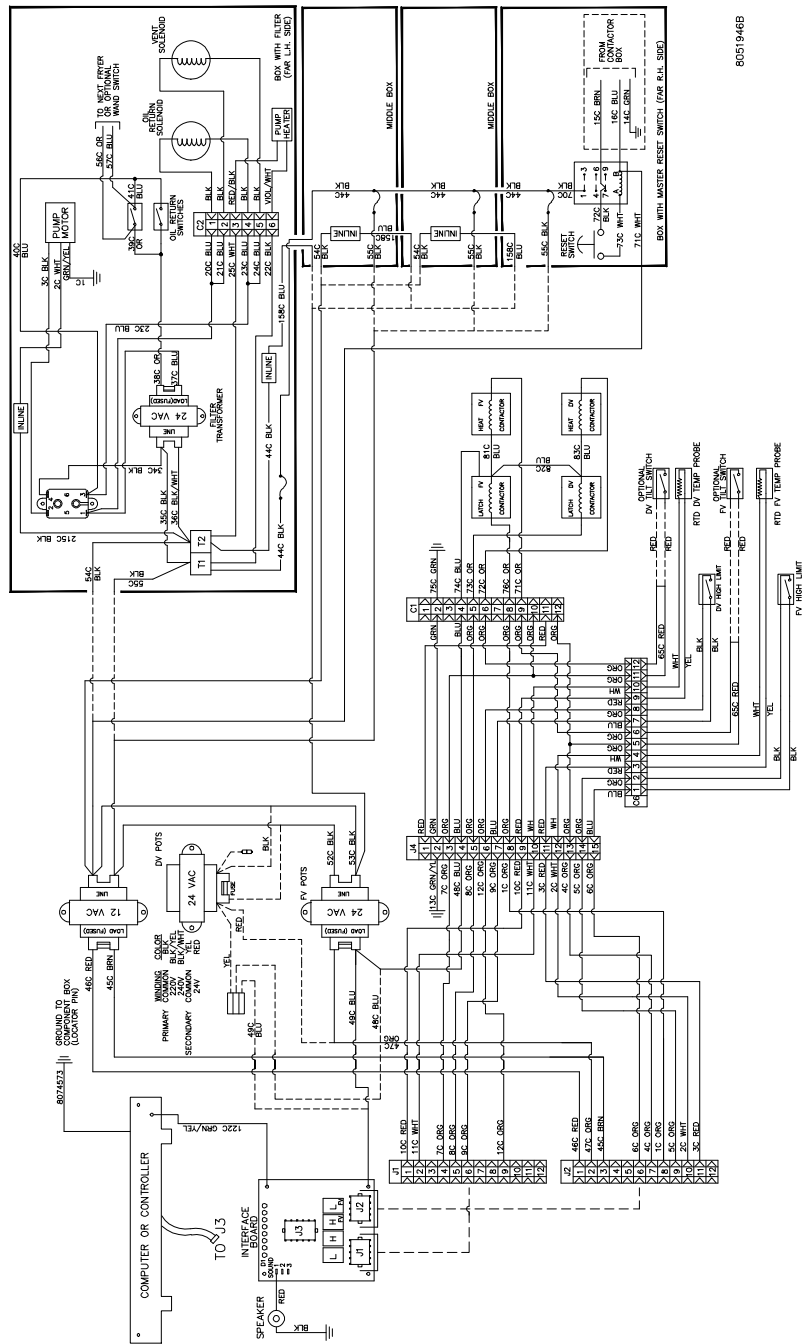

8001946B

1.3b Component Wiring with Manual LOV M3000 controller with LON

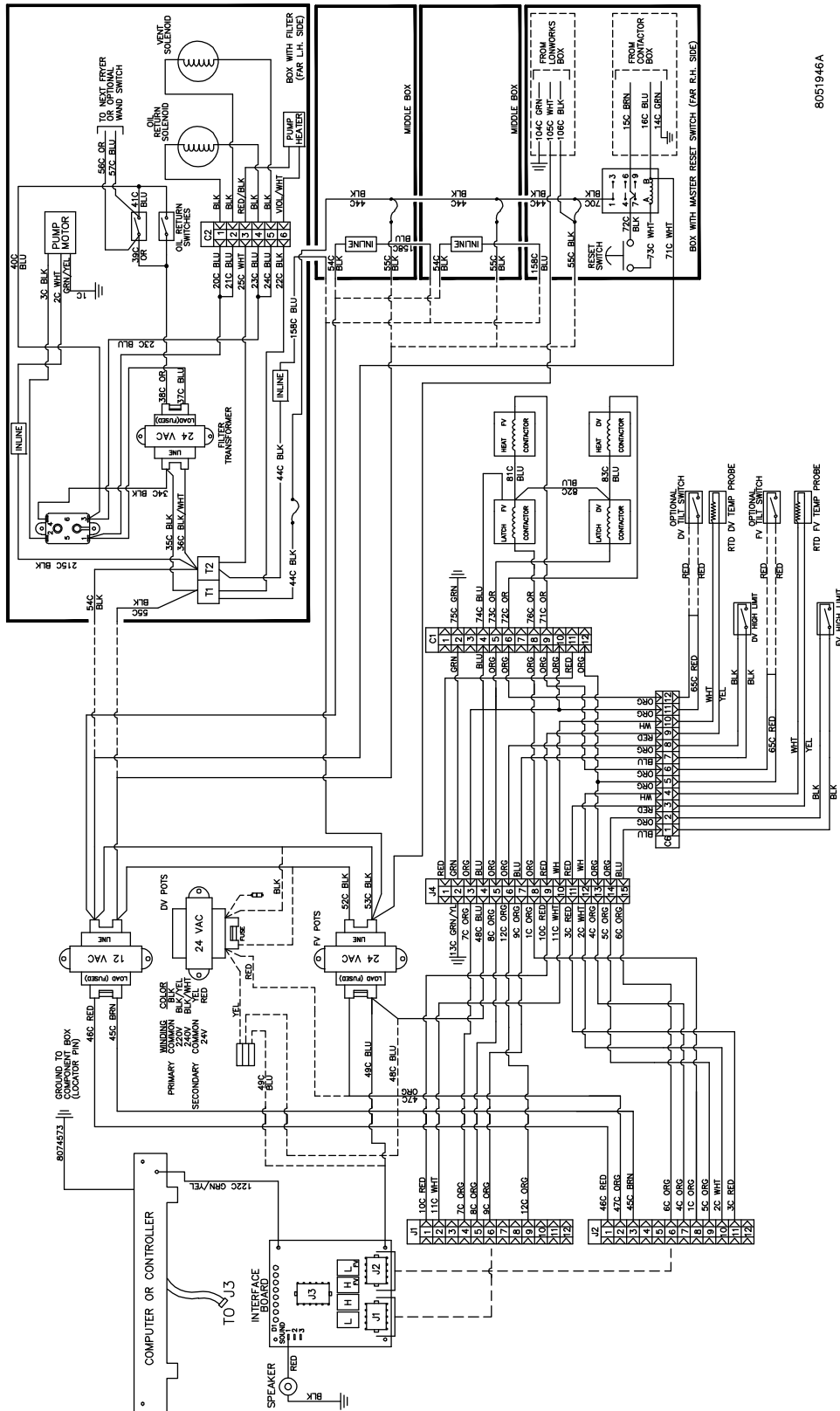

8051946A

1.4 Contactor Box – Delta Configuration

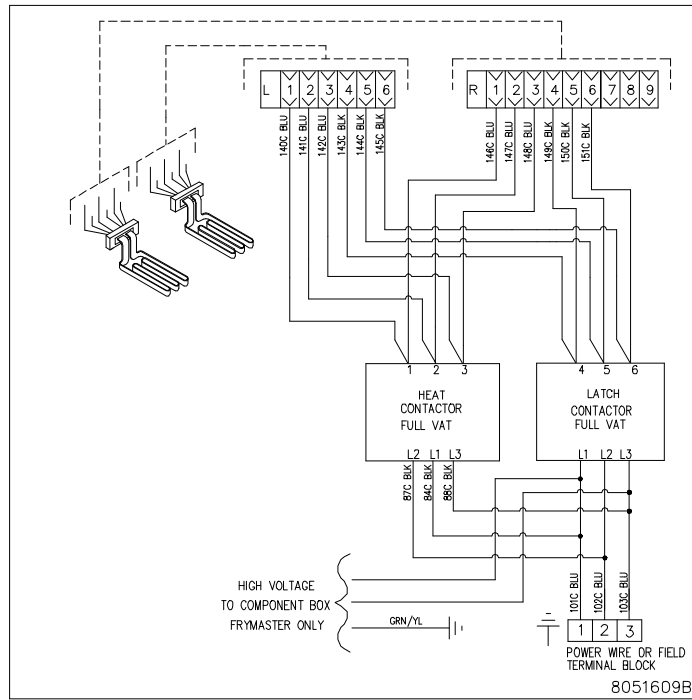

FULL VAT

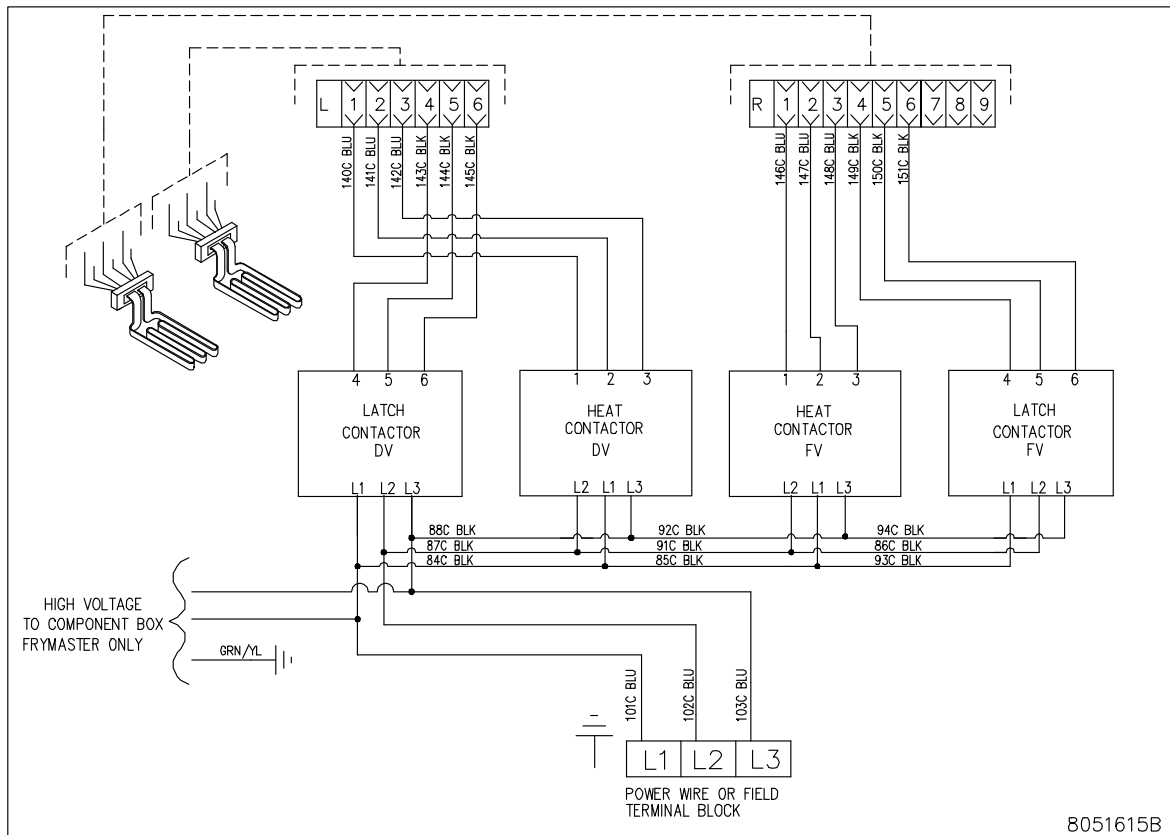

DUAL VAT

8051615B

1.5 Contactor Box – WYE Configuration

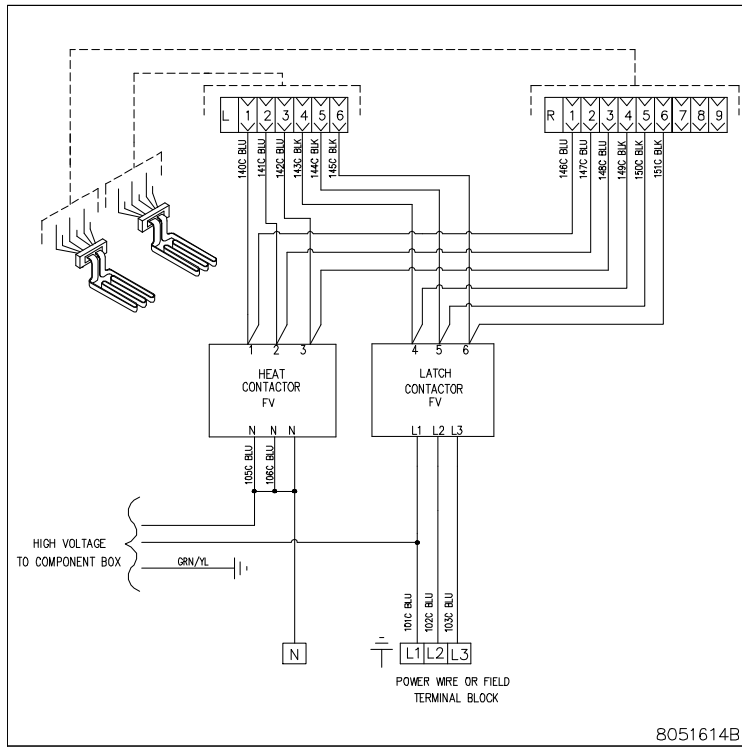

FULL VAT

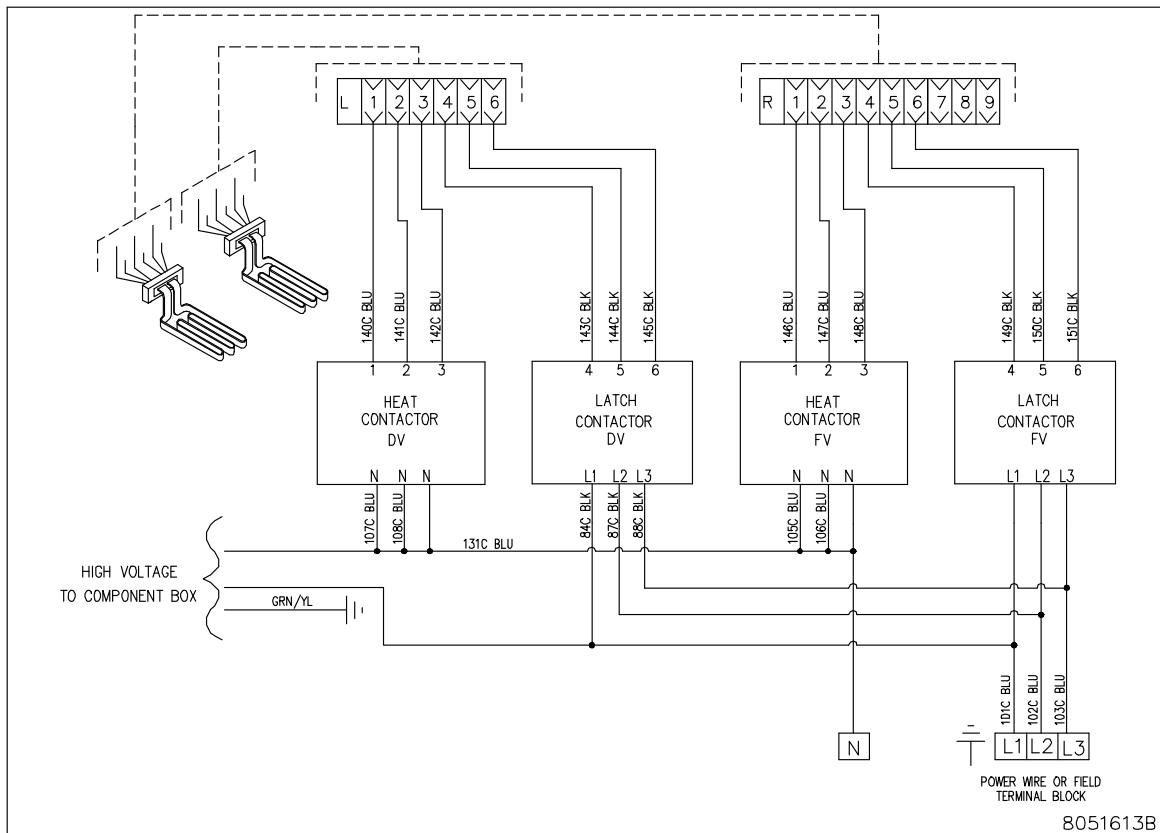

DUAL VAT

THIS PAGE INTENTIONALLY LEFT BLANK



FRYMASTER
8700 LINE AVENUE, SHREVEPORT, LA 71106-6800

318-865-1711
844-724-CARE (2273)
WWW.FRYMASTER.COM
EMAIL: SERVICE@FRYMASTER.COM



Every new piece of Manitowoc Foodservice equipment comes with KitchenCare™ and you choose the level of service that meets your operational needs from one restaurant to multiple locations.

StarCare – Warranty & lifetime service, certified OEM parts, global parts inventory, performance audited

ExtraCare – CareCode, 24/7 Support, online/mobile product information

LifeCare – Install & equipment orientation, planned maintenance, KitchenConnect™, MenuConnect

Talk with KitchenCare™ - 1-844-724-CARE - www.mtwkitchencare.com



To learn how Manitowoc Foodservice and its leading brands can equip you, visit our global web site at www.manitowocfoodservice.com, then discover the regional or local resources available to you.

